ITO FILM C8051F8XX EVALUATION KIT USER'S GUIDE

1. Introduction

The ITO Film Evaluation Kit (KeymatEK) implements a demo using a thin film or plastic printed with Indium Tin Oxide (ITO). The evaluation board features the Silicon Labs C8051F800 with Shin-Etsu "JCS" ITO Film material printed with a standard keymat pattern. The shapes, patterns, color ink graphics, and thicknesses of the film may all be customized for the application. For convenience, the board includes the Silicon Labs ToolStick Base Adapter circuitry for debugging, a CP210x USB-to-UART bridge for communication, and the QuickSense™ Firmware API for sensor performance monitoring and threshold adjustment.

2. Kit Contents

The ITO Film Evaluation Kit contains the following items:

- ITO Film Demo Board
- ITO Film Demo Board Quick Start Guide
- USB Cable

3. Getting Started

3.1. CP210x USB to UART VCP Driver Installation

The ITO Film Evaluation Board includes a Silicon Laboratories CP2103 USB-to-UART Bridge Controller. Device drivers for the CP2103 need to be installed before the PC software can communicate with the evaluation board over the USB connection. The CP210x Virtual COM Port (VCP) drivers can be downloaded from the Silicon Labs "Software Downloads" website (www.silabs.com/mcudownloads). After downloading the drivers, launch the "unpacker" utility.

1. Follow the steps to copy the driver files to the desired location. The default directory is *C:\SiLabs\MCU\CP210x*.
2. The final window will give an option to install the driver on the target system. Select the "Launch the CP210x VCP Driver Installer" option if you are ready to install the driver.
3. If selected, the driver installer will now launch, providing an option to specify the driver installation location. After pressing the "Install" button, the installer will search your system for copies of previously installed CP210x Virtual COM Port drivers. It will let you know when your system is up to date. The driver files included in this installation have been certified by Microsoft.
4. If the "Launch the CP210x VCP Driver Installer" option was not selected in step 3, the installer can be found in the location specified in step 2, by default *C:\SiLabs\MCU\CP210x\Windows_2K_XP_S2K3_Vista*. At this location, run *CP210xVCPInstaller.exe*.
5. If needed, the driver files can be uninstalled by selecting "Silicon Laboratories CP210x USB to UART Bridge Driver Removal" option in the "Add or Remove Programs" window.

3.2. Running the Demo

Follow these steps to run the ITO Film Evaluation Board Demo:

1. Install the Silicon Labs CP210x USB to UART VCP driver on the target PC following the directions in Section 3.1.
2. Once the VCP driver is installed, connect the F800 ITO Film Board COMM (P2) to the PC using a standard USB cable. The red PWR LED (DS5) should light up once the board is connected to the PC.

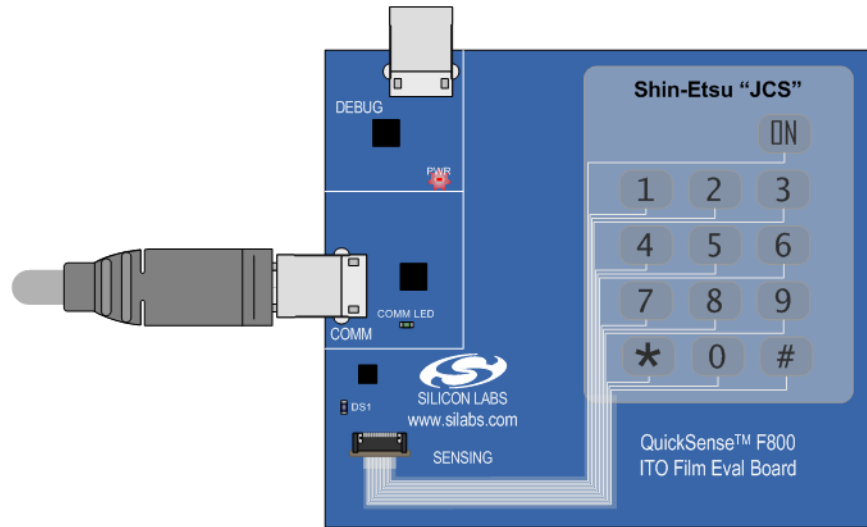

3. Wait until the green COMM LED (DS6) lights up. This indicates that the CP210x has enumerated and is ready to communicate with the PC.

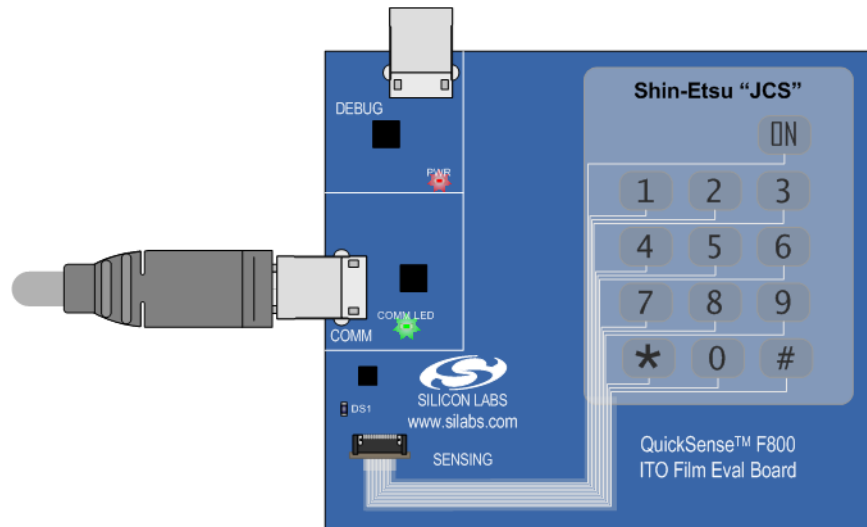

4. On the PC, install the Silicon Labs QuickSense Studio software package (www.silabs.com/quicksense).
5. Navigate to the software installation location (C:\SiLabsMCU\QuickSense_Studio\Software\PerformanceAnalysisTool\ by default) and run the QuickSense Performance Analysis Tool.

- In the Performance Analysis Tool, the “Devices” menu should contain the COM port associated with the CP2103 on the ITO Film Evaluation Board. Click the COM port and the software will automatically connect to the board.

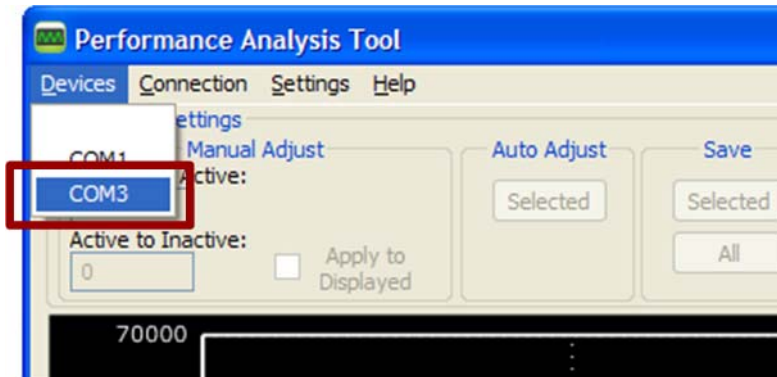

- To view the channel data in the Performance Analysis Tool, select a channel by clicking inside the white line surrounding the button. Press the “Start Acquisition” (Play) button. Then, press the appropriate button on the ITO Film Evaluation Board. The software will graph the thresholds and measured values for that button.

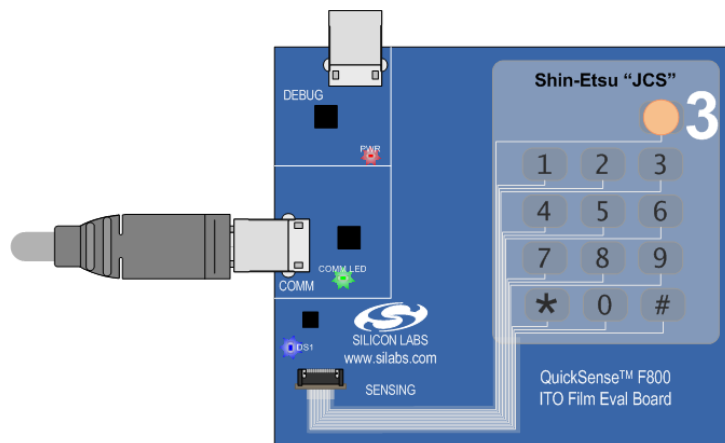
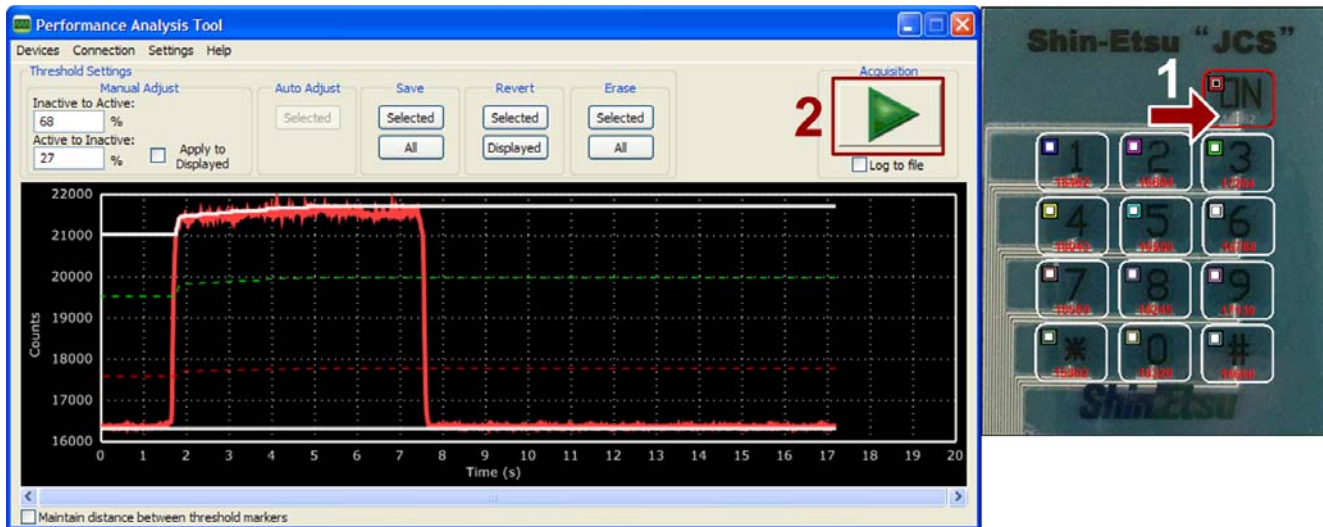

ITO Film-F800

8. The final demo setup should look as follows:

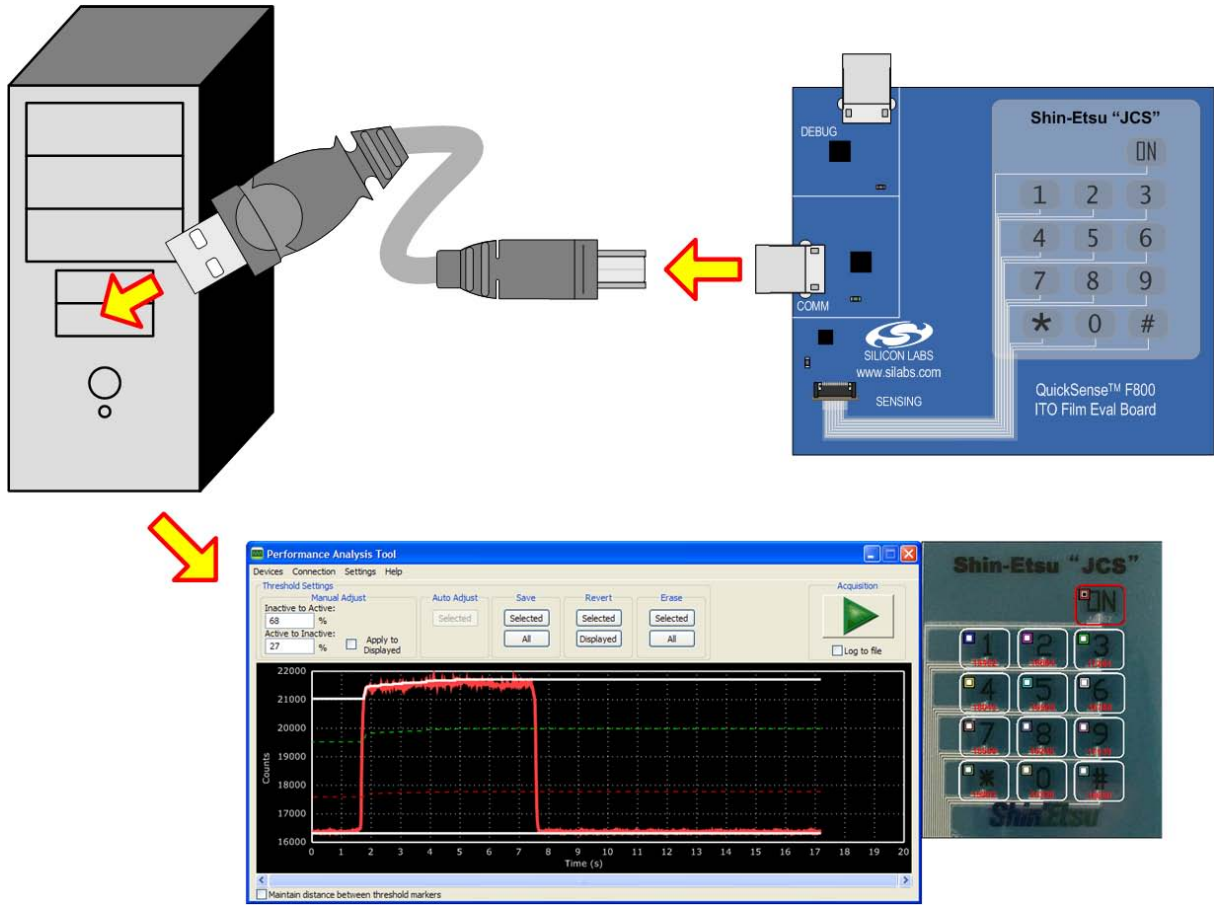

Figure 1. ITO Film Evaluation Board Demo Setup

4. Hardware Overview

The ITO Film Evaluation Board has three different areas: Sensing, Debug, and COMM.

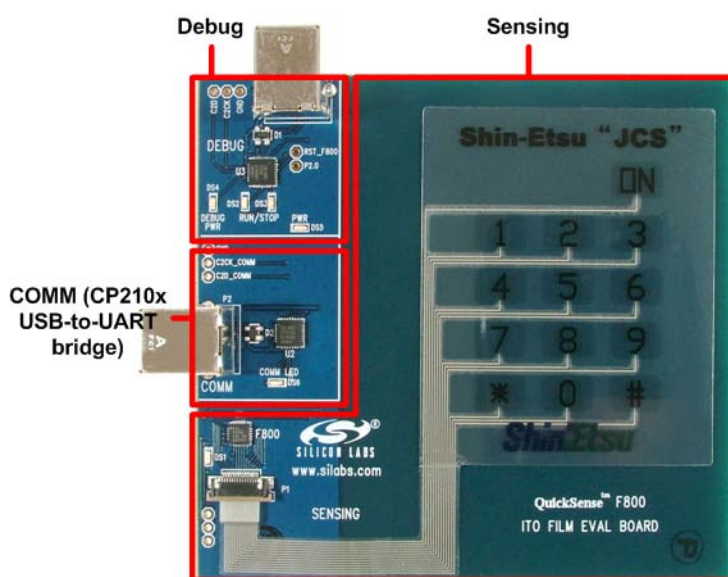

Figure 2. ITO Film Evaluation Board Hardware Overview

4.1. Sensing

The sensing area of the board includes the C8051F800 microcontroller, the ITO Film keypad, and one blue LED (DS1). The F800 performs all of the measuring, detection, and baselining using the QuickSense Firmware API. The LED (DS1) will light up when a finger is detected on one of the keypad buttons. The board can be monitored using the QuickSense Performance Analysis Tool available in the QuickSense Studio.

The F800 is powered from either the Debug or COMM USB connection. This can be modified using the R7 and R9 resistors and the Z1 and Z2 diodes by removing or populating these components as desired. The R7 and R9 resistors are populated and the Z1 and Z2 diodes are not populated by default.

The power consumption of the F800 can be measured independently of other circuitry on the board by removing the R3 resistor and placing an ammeter across the now-empty pads.

The ITO Film is provided by Shin-Etsu and includes a tail that matches the connector SFV14R-1STE1LF (FCI) on the PCB.

4.2. Debug

The debug area contains the ToolStick Base Adapter circuitry. In order to debug with the device, the P3 USB connector should be connected directly to the PC using a standard USB cable. A separate Debug Adapter should not be used. The Silicon Labs IDE can be used to connect to the device, download code to the device, and debug firmware.

4.3. COMM

COMM is the UART communications channel for the F800 on the board. The CP2103 converts the UART traffic to USB traffic and can be connected to on the PC using the CP210x USB-to-UART Virtual COM Port (VCP) drivers.

5. PC Software Overview

5.1. QuickSense™ Studio

The QuickSense Studio software facilitates rapid code development and analysis for applications using the Silicon Labs family of QuickSense products. The Studio is comprised of multiple programs that guide users through an intuitive development flow, including graphical configuration wizards, firmware templates, and performance monitoring tools. These programs interface with the QuickSense Firmware API, a highly configurable open-source firmware library that provides support for many different applications, from simple buttons to complex algorithms like gesture recognition.

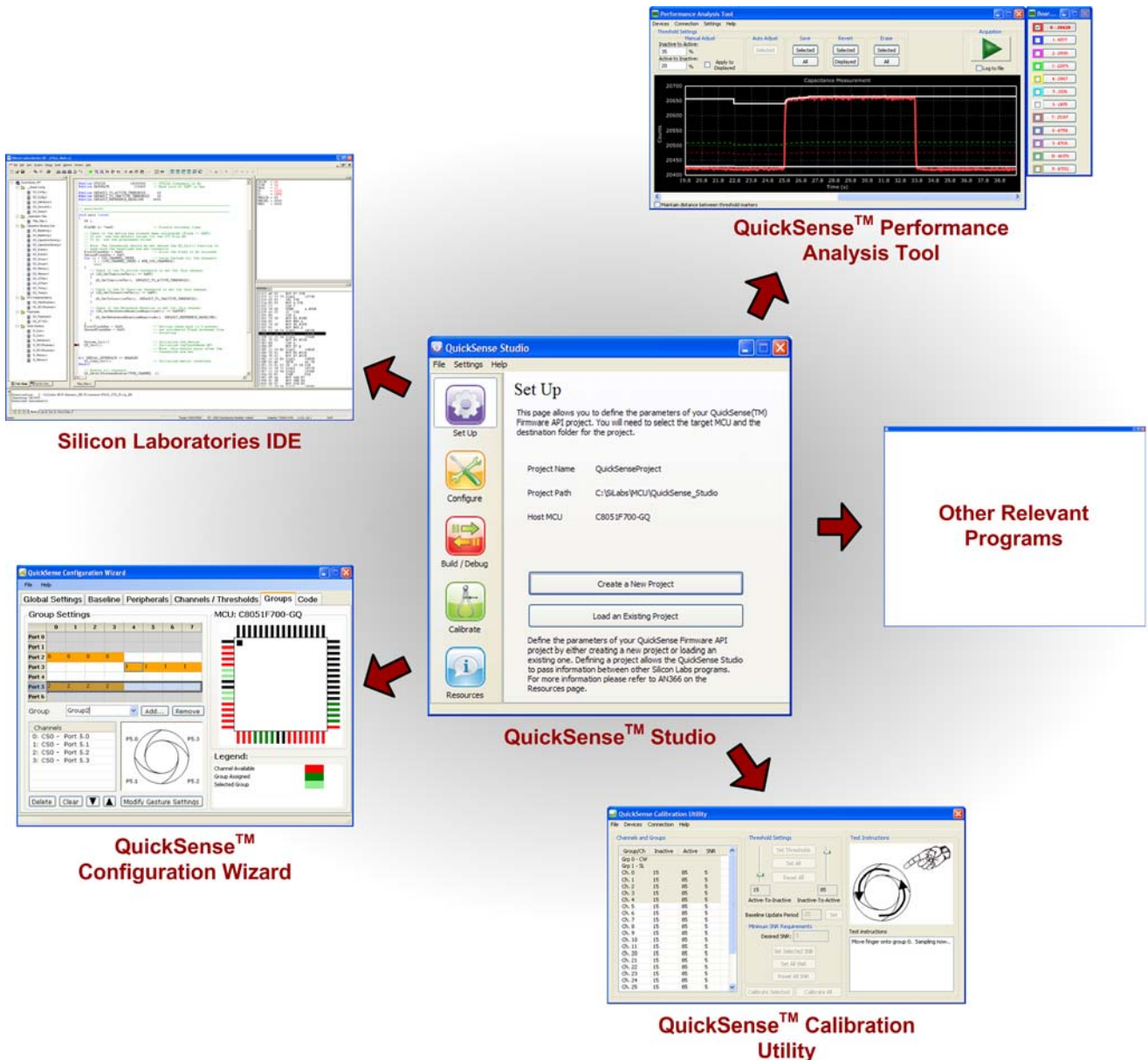

Figure 3. Silicon Labs QuickSense Studio Software

For detailed information on the QuickSense Studio software including the Performance Analysis Tool, please see the QuickSense Studio User's Guide available on the Silicon Labs QuickSense webpage (www.silabs.com/quick-sense) in the QuickSense Studio section.

5.2. Silicon Laboratories IDE

The Silicon Laboratories IDE integrates a source-code editor, a source-level debugger, and an in-system Flash programmer. When using the Silicon Labs IDE with the ITO Film Evaluation board, the setup should be as follows:

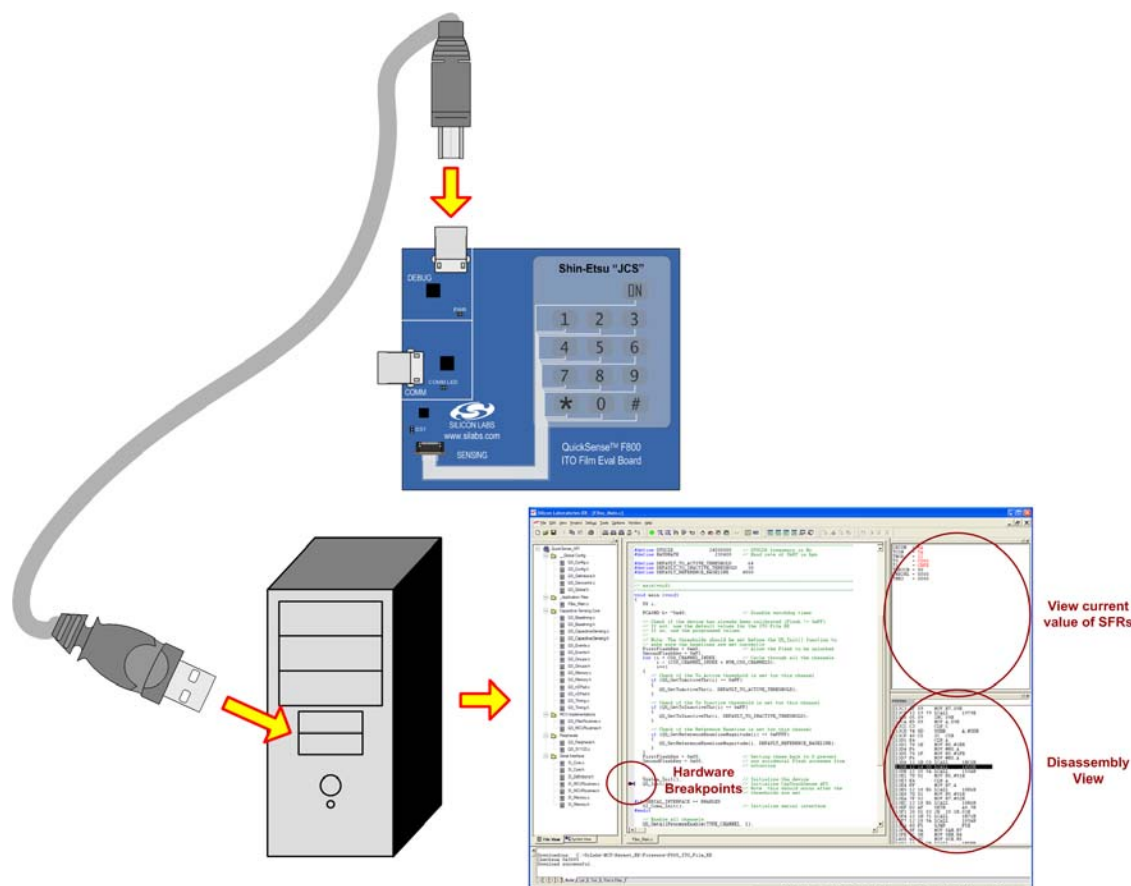

Figure 4. ITO Film Evaluation Board Debug Setup

5.2.1. IDE System Requirements

The Silicon Laboratories IDE requirements:

- Pentium-class host PC running Microsoft Windows 2000 or newer.
- One available USB port.

5.2.2. Downloading the Example Firmware Image

The ITO Film Evaluation Kit installer package installs the firmware source code as well as a pre-built Intel HEX (F800_ITO_Film_EK.hex) image that can be downloaded directly into the board. The firmware source code and an example IDE project is located in the default path `C:\SiLabs\MCU\QuickSense_Studio\Kits\KeymatEK\Firmware\`. The pre-built .HEX image is located in the default path `C:\SiLabs\MCU\QuickSense_Studio\Kits\KeymatEK\Firmware\Release\`. To update or refresh the .HEX image in the ITO Film Demo Board:

1. Connect the Debug USB port on the ITO Film Demo Board to the PC using a USB cable.
2. Launch the Silicon Labs IDE, and click on **Options**→**Connection Options**.
3. Select "USB Debug Adapter" and then select the board from the list (it should show up as "TSxxxx").

4. Select "C2" as the debug interface, and press "OK".
5. Connect to the board by pressing the "Connect" icon, or using the keyboard shortcut Alt+C.
6. Click on the "Download" icon, or use the keyboard shortcut Alt+D.
7. In the download dialog window, click "Browse".
8. Change to Files of Type "Intel Hex (*.hex)" and then browse to select the file F800_ITO_Film_EK.hex in the default path C:\SiLabs\MCU\QuickSense_Studio\Kits\KeymatEK\Firmware\Release\.
9. Click "Open" then "Download".
10. To run the new image, either press "Go" in the IDE or disconnect from the board (keyboard shortcut Alt+C). It is necessary to disconnect from the board in the IDE if the Performance Analysis Tool will be used to view data later.

6. Firmware Description

The ITO Film Demo Board firmware uses the QuickSense Firmware API to measure capacitance on the sensing pads and application layer code turns the board's LED on or off whenever a pad is pressed. The firmware provides the following functionality:

- Stores measured capacitance values from 13 ITO Film sensor pads.
- Compares measured capacitance values against calibrated thresholds to determine if buttons have been pressed.
- If a button's "active" or "inactive" threshold has been crossed, the API signals an application layer routine to update the blue LED (DS1).
- Using the Serial Interface part of the QuickSense Firmware API, the firmware transmits measured capacitance values across the CP210x USB-to-UART serial interface to the QuickSense development and display tools.
- Baseline algorithm reduces effects of environmental changes such as temperature and humidity on sensing pad sensitivity.

Figure 5 shows the mapping of the ITO Film sensor pads to QuickSense Firmware API project input channels.

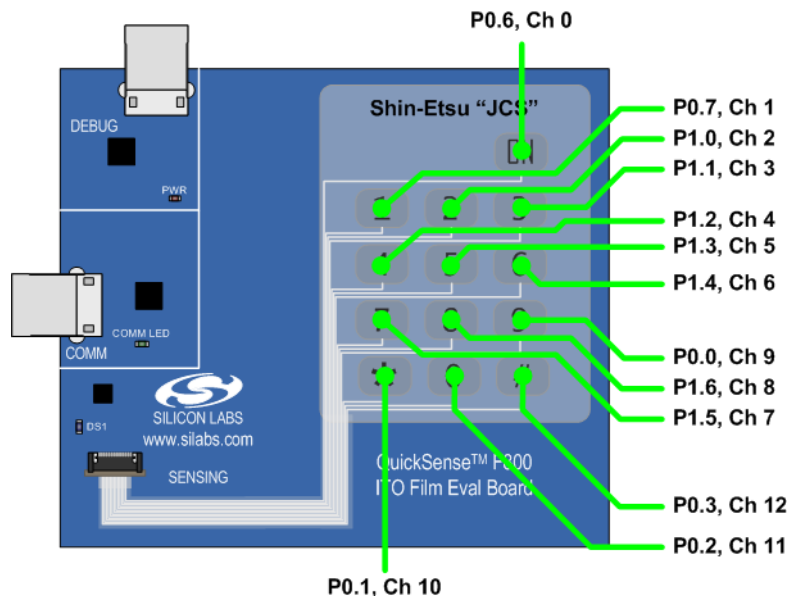

Figure 5. Mapping of Capacitive Sensing Pads to Port Pins and Firmware Input Channels

For a more detailed description of the QuickSense Firmware API or the Serial Interface, see "AN366: QuickSense API." For a more detailed description of active/inactive thresholds, see "AN367: Understanding Capacitive Sensing Signal to Noise Ratios." For a discussion on baselining in the QuickSense Firmware API, see "AN418: Baselining in the QuickSense Firmware API."

7. Schematics

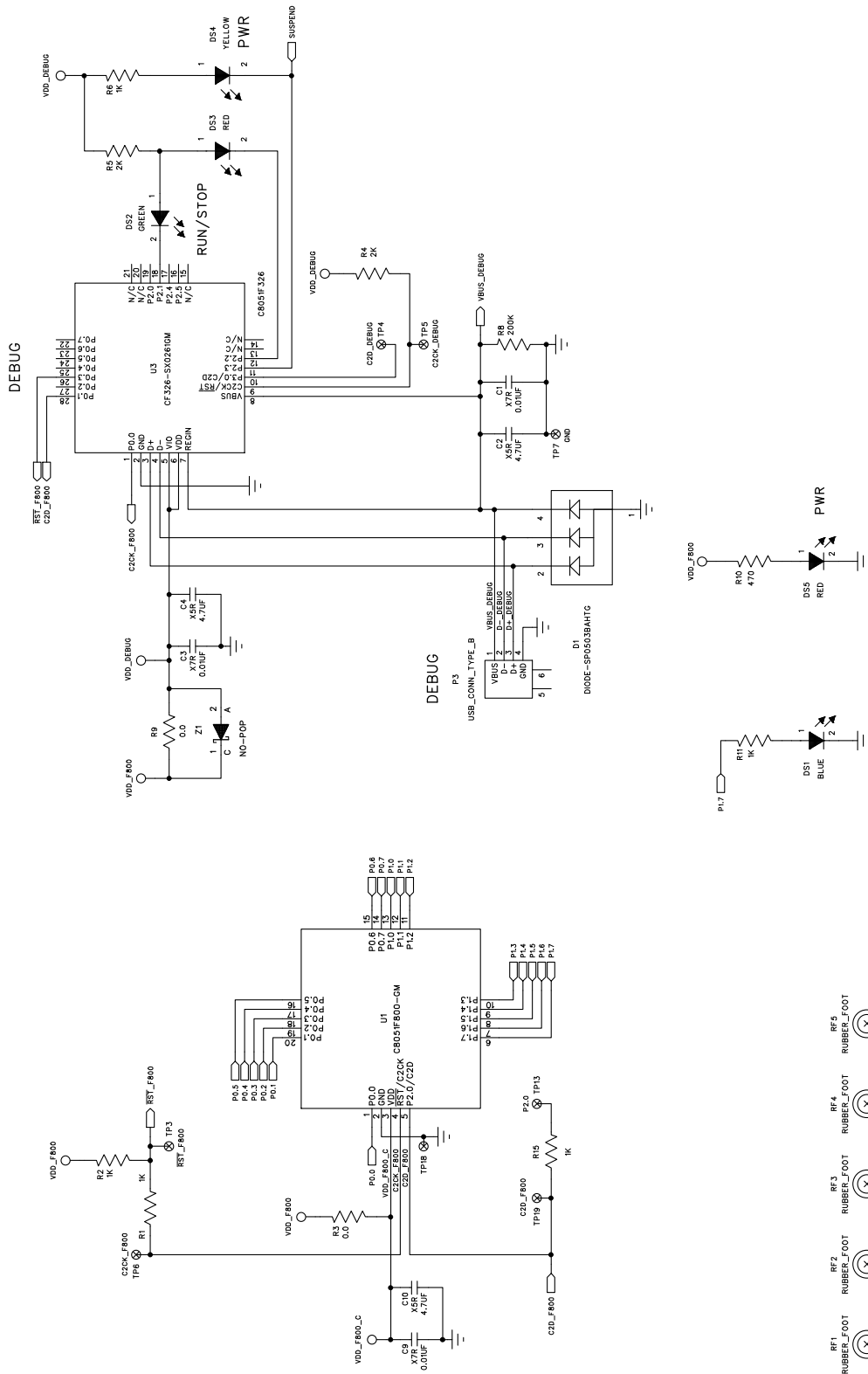

Figure 6. QuickSense C8051F800 ITO Film Evaluation Board (1 of 2)

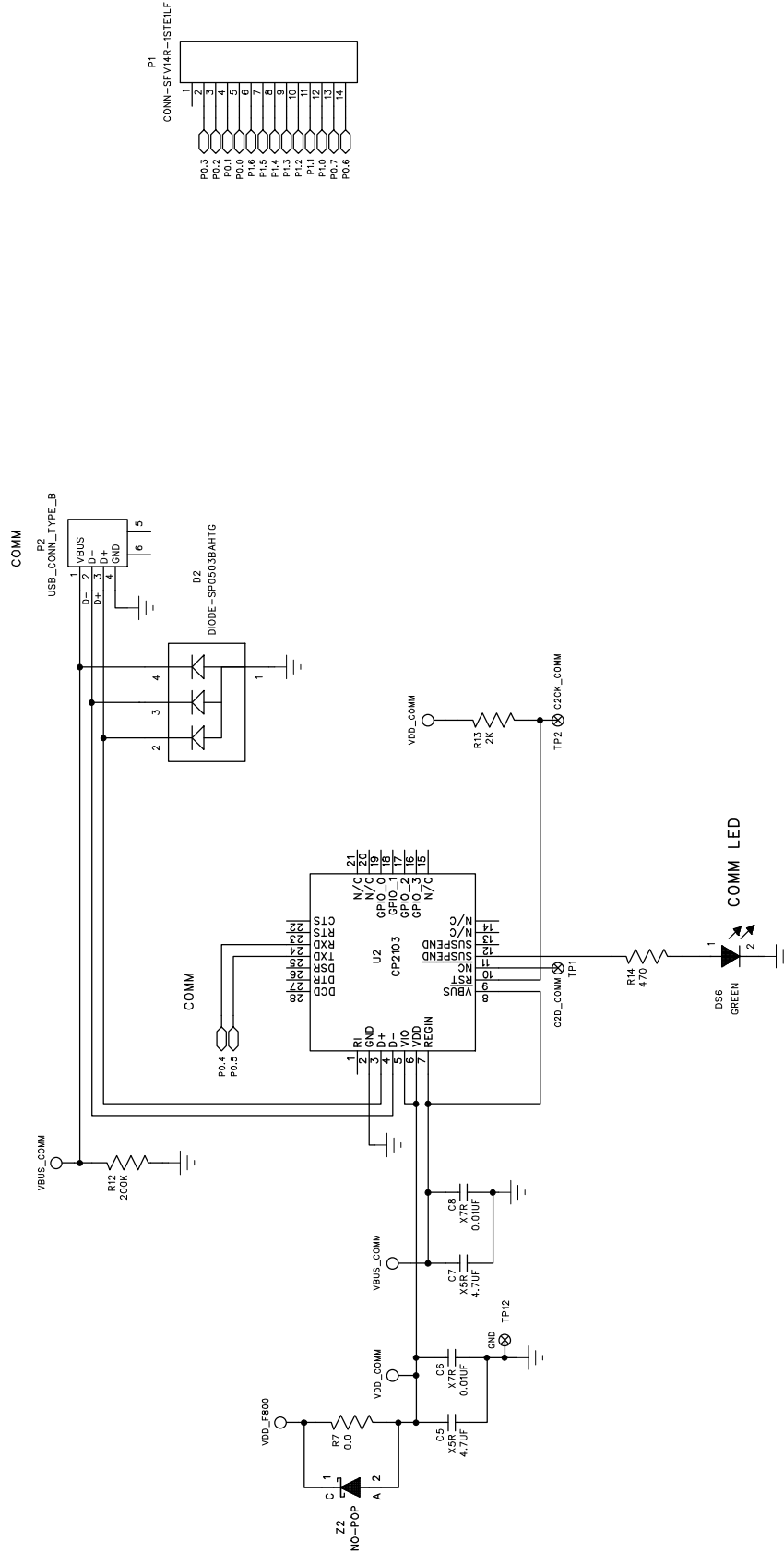

Figure 7. QuickSense C8051F800 ITO Film Evaluation Board (2 of 2)

NOTES:

CONTACT INFORMATION

Silicon Laboratories Inc.
400 West Cesar Chavez
Austin, TX 78701
Tel: 1+(512) 416-8500
Fax: 1+(512) 416-9669
Toll Free: 1+(877) 444-3032

Please visit the Silicon Labs Technical Support web page:
<https://www.silabs.com/support/pages/contacttechnicalsupport.aspx>
and register to submit a technical support request.

The information in this document is believed to be accurate in all respects at the time of publication but is subject to change without notice. Silicon Laboratories assumes no responsibility for errors and omissions, and disclaims responsibility for any consequences resulting from the use of information included herein. Additionally, Silicon Laboratories assumes no responsibility for the functioning of undescribed features or parameters. Silicon Laboratories reserves the right to make changes without further notice. Silicon Laboratories makes no warranty, representation or guarantee regarding the suitability of its products for any particular purpose, nor does Silicon Laboratories assume any liability arising out of the application or use of any product or circuit, and specifically disclaims any and all liability, including without limitation consequential or incidental damages. Silicon Laboratories products are not designed, intended, or authorized for use in applications intended to support or sustain life, or for any other application in which the failure of the Silicon Laboratories product could create a situation where personal injury or death may occur. Should Buyer purchase or use Silicon Laboratories products for any such unintended or unauthorized application, Buyer shall indemnify and hold Silicon Laboratories harmless against all claims and damages.

Silicon Laboratories, Silicon Labs, and QuickSense are trademarks of Silicon Laboratories Inc.
Other products or brandnames mentioned herein are trademarks or registered trademarks of their respective holders.

Mouser Electronics

Authorized Distributor

Click to View Pricing, Inventory, Delivery & Lifecycle Information:

[Silicon Laboratories:](#)

[KEYMATEK](#)